

PRODUCT DATA SHEET

ISD9203B Sensor

Wideband Frequency, Intrinsically Safe Sensor

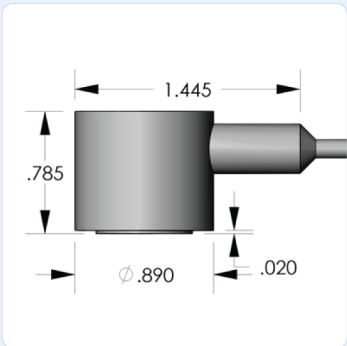

DESCRIPTION AND FEATURES

The ISD9203B is a wideband frequency sensor that was designed specially to meet Intrinsic Safety (IS) and IP65 environmental requirements. Certified as Intrinsically Safe (IS) for use with our 1276-2 IS preamplifier and 1276-1 and 1278 IS ASL-C subsystem, this sensor has a thicker ceramic wear-plate and an epoxy coating completely covering the sensor and cable exit. An IS voltage protection circuit is built into the sensor.

It has an integrated one-meter long differential cable with extruded TPE jacket and a pigtail for connecting into a 1276 or 1278 IS Preamplifier or Subsystem. The sensor has similar frequency response as the D9203B sensor. Its maximum operating temperature is 125°C.

APPLICATIONS

Wideband sensors are typically used in research applications or other applications where a high fidelity AE response is required. In research applications, wideband AE sensors are useful where frequency analysis of the AE signal is required and in helping determine the predominant frequency band of AE sources for noise discrimination and selection of a suitable lower cost, general purpose AE sensor. In high fidelity applications, various AE wavemodes can be detected using wideband sensors, providing more information about the AE source and distance of the AE event.

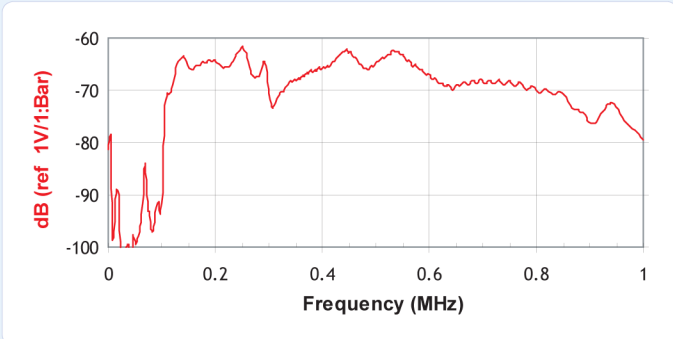

OPERATING SPECIFICATIONS

Dynamic

Peak Sensitivity, Ref V/(m/s)	65 dB
Peak Sensitivity, Ref V/ μ bar	-60 dB
Operating Frequency Range	150-850 KHz
Resonant Frequency, Ref V/(m/s)	175 dB
Resonant Frequency, Ref V/ μ bar	500 KHz
Directionality	+/- 1.5 dB

Environmental

Temperature Range	-45 to 125°C
Shock Limit	1,000 g
Completely enclosed crystal for RFI/EMI immunity	

Physical

Dimensions	0.89"OD X 0.755" H
	22.6 mm OD X 19.2 mm H
Weight	27 grams with 1 meter cable
Case Material	Stainless steel/Epoxy
Face Material	Ceramic
Connector	Pigtail
Connector Locations	Side Seal
Sensor to Preamp Cable (1 meter)	Integral

Certifications

ATEX Certified

ORDERING INFORMATION AND ACCESSORIES

ISD9203B	ISD9203B
Pre-amplifier	1276-2
ASL-4-20 ma Subsystem	1276-1
Preamp to System Cable (specify length in 'm')	1276C
IS Zener Barrier	1276B
Other IS Sensors are available with various resonant frequencies.	

Sensors include

NIST Calibration Certificate & Warranty

