

PRODUCT DATA SHEET

ISR30 Sensor

Intrinsically Safe Sensor

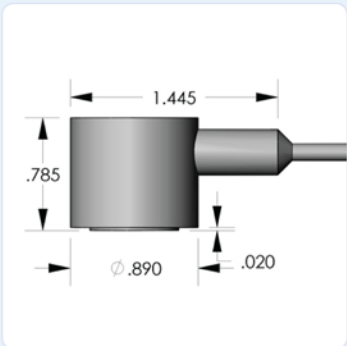

DESCRIPTION AND FEATURES

The ISR30 is a 300 kHz resonant frequency sensor that was designed specially to meet Intrinsic Safety (IS) and IP66 environmental requirements. Certified as Intrinsically Safe (IS) for use with our 1276-2 IS preamplifier and 1276-1 and 1278 IS ASL-C subsystem, this sensor has a thicker ceramic wear-plate and an epoxy coating completely covering the sensor and cable exit. An IS voltage protection circuit is built into the sensor.

It has an integrated one-meter long differential cable with extruded TPE jacket and a pigtail for connecting into a 1276 or 1278 IS Preamplifier or Subsystem. The sensor has similar frequency response as the R30 sensor. Its maximum operating temperature is 125°C.

APPLICATIONS

This sensor provides additional noise rejection for applications such as production line process monitoring applications such as punch press monitoring, forming operations, stamping, applications and process control applications such as leak detection within process control plants in the presence of flow and process noises, where intrinsically safe sensors and systems are required.

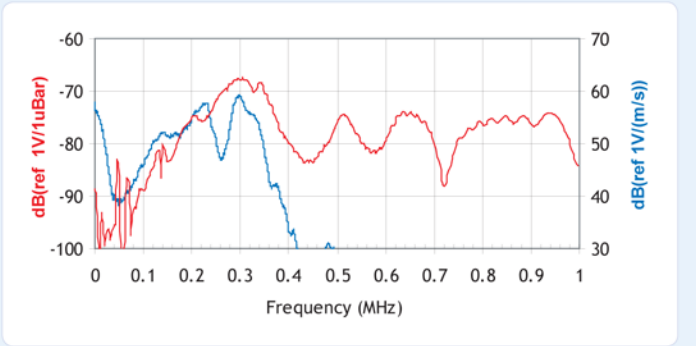

OPERATING SPECIFICATIONS

Dynamic

Peak Sensitivity, Ref V/(m/s).....	58 dB
Peak Sensitivity, Ref V/ μ bar.....	-64 dB
Operating Frequency Range.....	150-400 KHz
Resonant Frequency, Ref V/(m/s).....	300 dB
Resonant Frequency, Ref V/ μ bar.....	350 KHz
Directionality.....	+/- 1.5 dB

Environmental

Temperature Range.....	-45 to 125°C
Shock Limit.....	1,000 g
Waterproof.....	IP66
Completely enclosed crystal for RFI/EMI immunity	

Physical

Dimensions.....	0.89"OD X 0.755"H
	22.6 mm OD X 19.2 mm H
Weight.....	27 grams with 1 meter cable
Case Material.....	Stainless steel/Epoxy
Face Material.....	Ceramic
Connector.....	Pigtail
Connector Locations.....	Side
Seal.....	Epoxy
Sensor to Preamp Cable (1 meter).....	Integral

Certifications

ATEX Certified, II1, GD, EEx, ia, IIC T4

ORDERING INFORMATION AND ACCESSORIES

ISR30.....	ISR30
Pre-amplifier.....	1276-2
ASL-4-20 ma Subsystem.....	1276-1
Preamp to System Cable (specify length in 'm').....	1276C
IS Zener Barrier.....	1276B
Other IS Sensors are available with various resonant frequencies.	

Sensors include

NIST Calibration Certificate & Warranty

