

PRODUCT DATA SHEET

R6I-UC Sensor

Underwater Sensor

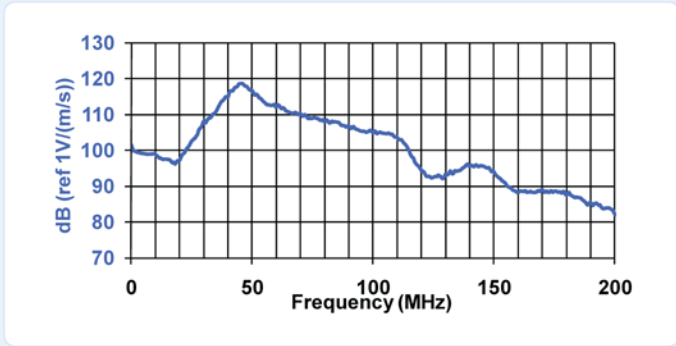
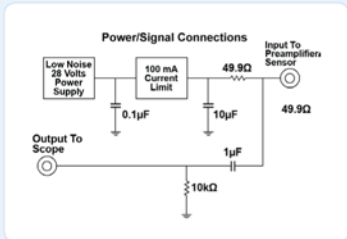
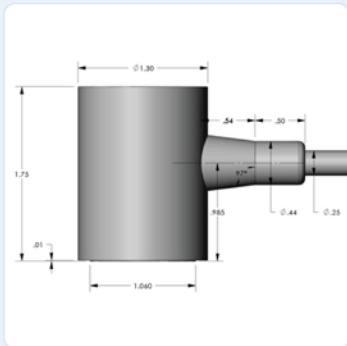

DESCRIPTION AND FEATURES

R6I-UC is an underwater sensor with integrated preamplifier. It is a narrowband sensor with very high sensitivity featuring an integral preamplifier with a gain of 40 dB. The integrated electronics give the sensor a signal-to-drive capability for depths of 300 meters (1000 ft) or more. The sensors feature special polymer coatings making it 100% insulated and non conductive with an integral waterproof cable for underwater use. The sensor is tested to depths of 1000 psi.

APPLICATIONS

The sensor can be used for the structural health monitoring of submerged structures like offshore oil and gas platforms, ships etc. They can be used inside any liquid filled platforms like pipelines, chemical tanks or any other submerged structures.

OPERATING SPECIFICATIONS

Dynamic

Peak Sensitivity, Ref V/(m/s).....	120 dB
Peak Sensitivity, Ref V/µbar.....	-26 dB
Operating Frequency Range.....	35-100 KHz
Resonant Frequency, Ref V/(m/s).....	50 dB
Resonant Frequency, Ref V/µbar.....	90 KHz
Directionality.....	+/- 1.5 dB

Environmental

Temperature Range.....	-30 to 65°C
Shock Limit.....	500 g
Completely enclosed crystal for RFI/EMI immunity	

Physical

Dimensions.....	1.31"OD X 1.66"H
.....	33 mm OD X 42 mm H
Weight.....	116 grams
Case Material.....	Stainless Steel/Epoxy
Face Material.....	Ceramic
Connector.....	BNC on integral cable
Connector Locations.....	Side

Electrical

Gain.....	40 dB
Power Requirements.....	20-30 VDC @ 25 mA
Dynamic Range.....	> 87 dB
Noise Level (RMS RTI).....	< 3 µV
Output Drive Impedance.....	50 Ω
Grounding.....	Case Grounding
.....	Isolated from mounting surface

ORDERING INFORMATION AND ACCESSORIES

R6I-UC.....	R6I-UC
Preamp to System Cable (specify length in 'm').....	1234-X
Amplifier Subsystems.....	AE2A, AE5A

Sensors include

NIST Calibration Certificate & Warranty

